

à billes de l'autre main. Soulevez la chaîne à billes hors de la rainure de verrouillage des billes et faites glisser le dispositif de tension jusqu'au bas de la boucle de la chaîne.

Tirez le dispositif de tension vers le bas jusqu'à ce que la chaîne à billes soit complètement tendue (le piston sera en haut), puis déplacez le dispositif de tension vers le haut d'environ 1/8".

Marquez les emplacements des vis sur le mur ou le cadre de la fenêtre avec un crayon.

Montage intérieur: en cas de montage dans du bois, pré-percez les trous de vis, puis installez le dispositif de tension à l'aide des vis à tête Phillips de 1 pouce fournies.

Si vous ne le fixez pas dans le bois, utilisez des ancrages appropriés au substrat et suivez les instructions du fabricant des ancrages.

Montage extérieur: déplacez le dispositif de tension vers le bas de la chaîne comme indiqué ci-dessus. Appuyez ensuite le dispositif de tension sur les poteaux du support de montage. Installez soigneusement les vis à tête Phillips 3/8» fournies à travers le dispositif de tension dans le support de montage à l'aide d'un tournevis cruciforme (NE PAS TROP SERRER !). Tirez le dispositif de tension vers le bas comme indiqué ci-dessus et marquez au crayon la position du support de montage extérieur. Détachez maintenant le dispositif de tension du support, marquez au crayon les emplacements des vis du support et fixez-le à l'aide des vis de 1», puis rattachiez le dispositif de tension au support.

Fonctionnement du store

L'exposition limitée du cordon est une mesure de sécurité requise. Par conséquent, le cordon doit être tiré plusieurs fois pour soulever ou abaisser le store. Soyez patient, tirez le cordon lentement et doucement pour prolonger la durée de vie du store.

SUPPLEMENTARY INSTALLATION INSTRUCTIONS FOR CUSTOMERS IN CANADA

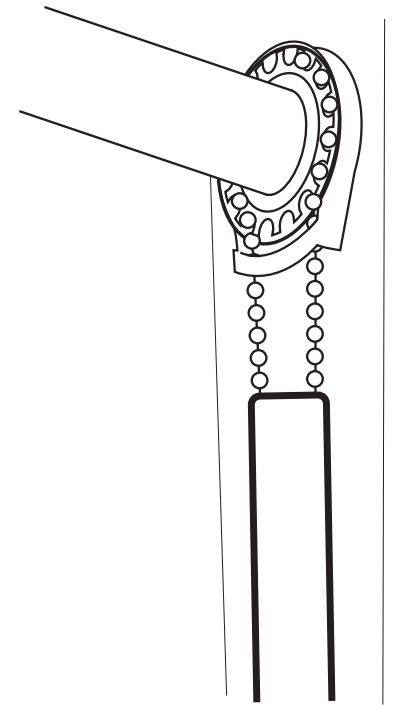

Installing Shades with a Chain Cover

Your new shade includes a dedicated lift cord/chain cover that allows for no more than 22cm (8") of lift cord to be exposed at any time. The cover is pre-attached to the beaded chain lift cord.

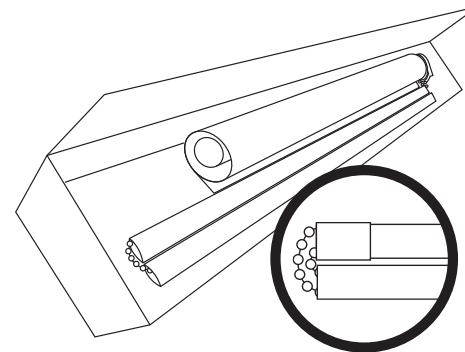

The cover for larger shades will be in two sections which are separated when the shade is packaged for shipment and thus must be joined together when the shade is

installed. See complete instructions below:

Step 1 – Carefully remove the protective bubble wrap from both ends of the shade. Do not remove the bubble wrap at the center of the shade until the shade is fully installed. Unwrap the Bead Chain and Tension Device being certain not to damage the chain. Cut and remove the zip-tie.

Step 2 – Attach the shade using the detailed instructions that came with the shade. Allow the chain, chain cover and tension device to hang freely when mounting the shade.

Step 3 – If the Chain Cover is in two sections, attach the sections as illustrated.

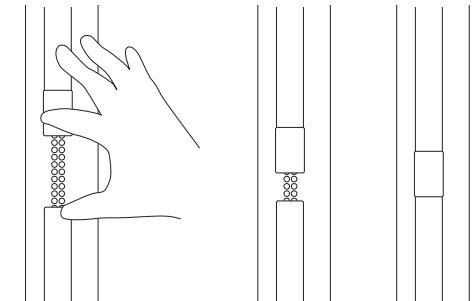

Slide the bottom section of the Chain Cover into the Connector that is pre-attached to the upper section

Step 4 – Attach the Tension Device

IMPORTANT – The Tension Device must be attached as detailed in these instructions for your shade to function properly.

If possible, have a helper hold the Chain Cover up and out of the way when installing the Tension Device.

While holding the tension device in one hand, pull the plunger away from the bead chain with the other hand. Lift the bead chain out of the bead locking groove and slide the tension device to the bottom of the chain loop.

Pull the tension device down until the bead chain is fully tensioned (plunger will be at

STRANGULATION HAZARD – Young children can be strangled by cords. Immediately remove this product if a cord longer than 22 cm or a loop exceeding 44 cm around becomes accessible.

RISQUE D'ÉTRANGLEMENT – Les enfants en bas âge peuvent s'étrangler avec des cordes. Enlevez immédiatement ce produit si une corde mesurant plus de 22 cm devient accessible ou si le contour d'une boucle de plus de 44 cm devient accessible.

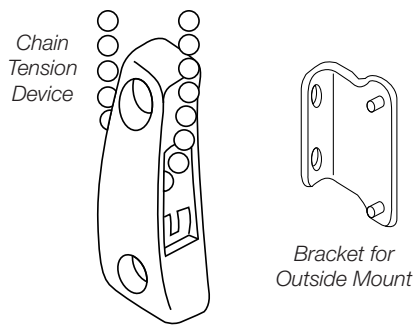

mark the screw locations for the bracket and attach it using the 1" screws, and then reattach the tension device to the bracket.

Operating the Shade

The limited cord exposure is a required safety measure. As a result, the cord must be pulled many times to lift or lower the shade. Be patient, pull the cord slowly and smoothly to prolong the life of the shade.

the top) and then move the tension device up approximately 1/8".

Mark the screw locations on the wall or window frame with a pencil.

Inside Mount: If mounting into wood, predrill screw holes and then install the tension device using the 1" Phillips head screws provided.

If not securing into wood, use appropriate anchors for the substrate and follow the anchor manufacturer's instructions.

Outside Mount: Move the tension Device to the bottom of the chain as noted above. Then press the tension device onto the mounting bracket posts. Carefully install the 3/8" Phillips head screws provided through the tension device into the mounting bracket using a Phillips head screwdriver (DO NOT OVER-TIGHTEN!). Pull the tension device down as noted above and pencil mark the position of the outside mount bracket. Now detach the tension device from the bracket, pencil

STRANGULATION HAZARD — Young children can be strangled by cords. Immediately remove this product if a cord longer than 22 cm or a loop exceeding 44 cm around becomes accessible.

RISQUE D'ÉTRANGLEMENT — Les enfants en bas âge peuvent s'étrangler avec des cordes. Enlevez immédiatement ce produit si une corde mesurant plus de 22 cm devient accessible ou si le contour d'une boucle de plus de 44 cm devient accessible.

INSTRUCTIONS D'INSTALLATION SUPPLÉMENTAIRES POUR LES CLIENTS AU CANADA

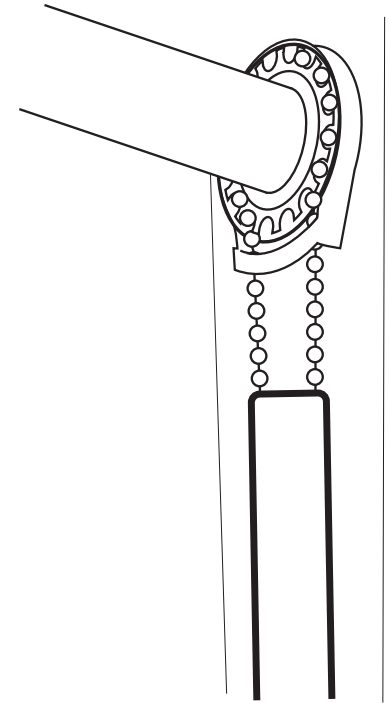

séparées lorsque le store est emballé pour l'expédition et doivent donc être assemblées lorsque le store est installé. Voir les instructions complètes ci-dessous :

étape 1 – Retirez délicatement le film protecteur à bulles des deux extrémités du store. Ne retirez pas le papier bulle au centre du store tant que le store n'est pas complètement installé. Déballez la chaîne à billes et le dispositif de tension en vous assurant de ne pas endommager la chaîne. Coupez et retirez l'attache zippée.

étape 2 – Fixez le store en suivant les instructions détaillées fournies avec le store. Laissez la chaîne, le couvercle de chaîne et le dispositif de tension pendre librement lors du montage du store.

étape 3 – Si le couvre-chaîne est composé de deux sections, fixez les sections comme illustré.

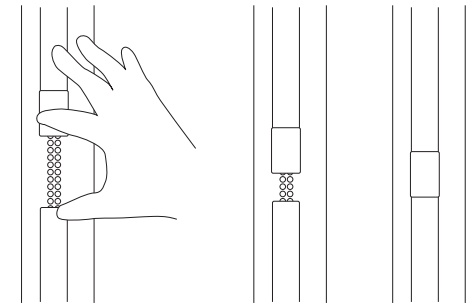

Installation de stores avec un couvre-chaîne

Votre nouveau store comprend un couvre-cordon/chaîne de levage dédié qui permet d'exposer à tout moment un maximum de 22 cm (8") de cordon de levage. La housse est pré-attachée au cordon de levage à chaîne perlée.

Faites glisser la section inférieure du couvercle de chaîne dans le connecteur pré-attaché à la section supérieure.

étape 4 – Fixez le dispositif de tension

IMPORTANT– Le dispositif de tension doit être fixé comme détaillé dans ces instructions pour que votre store fonctionne correctement.

Si possible, demandez à une personne de maintenir le couvercle de chaîne vers le haut et à l'écart lors de l'installation du dispositif de tension.

Tout en tenant le dispositif de tension d'une main, éloignez le piston de la chaîne

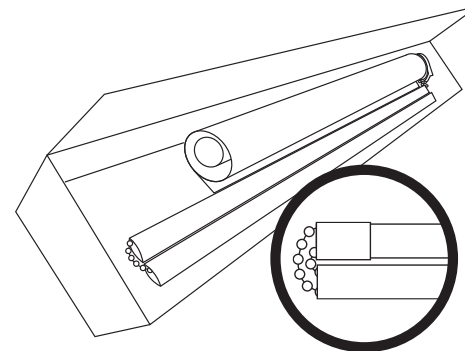

La couverture des stores plus grands sera composée de deux sections qui sont

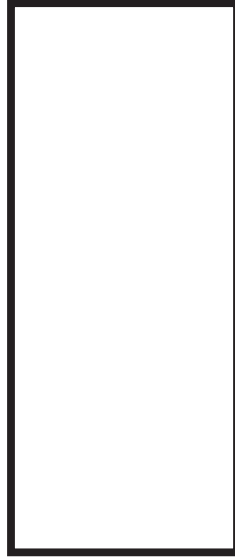

 **SelectBlinds®**

Essential Dual Shade

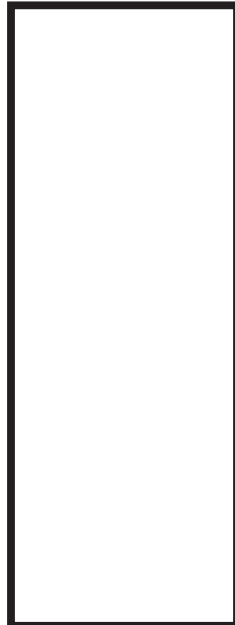

Warranty Remedy: This shall be your sole remedy under this limited warranty. If this product is found to have a manufacturing defect in materials or workmanship, we will, at our discretion, do one of the following:

- Repair the product
- Replace the product
- Refund the cost of the product.

Colors may vary from lot to lot and may not exactly match sample swatches or previous purchases.

Discontinued items or color selections will be replaced with the closest equivalent current product.

Your rights under state law: This lifetime limited warranty gives you specific legal rights, and you may have other rights which vary from state to state. Some states do not allow limitations on how long a warranty lasts, so the above limitations may not apply to you. No agent, representative, dealer or unauthorized employee has the authority to increase or alter the obligation of this warranty. This lifetime limited warranty supersedes any previous versions.

WARNING

STRANGULATION HAZARD — Young children can be strangled by cords. Immediately remove this product if a cord longer than 22 cm or a loop exceeding 44 cm around becomes accessible.

Cordless Dual Shade

INSTALLATION INSTRUCTIONS

Step 1. Check Package Contents

Missing part? Call 1-800-264-1190
Mounting hardware kit includes the following:

Part	Quantity
a. Mounting Brackets	2 shades up to 45" wide 3 up to 72" wide
b. Extension Brackets (for outside mounts)	2 shades up to 45" wide 3 up to 72" wide
c. Screws	4 shades up to 45" wide 6 up to 72" wide
d. Wall Anchors	4 shades up to 45" wide 6 up to 72" wide
e. Handle for Bottom Rail	1 shades up to 48" wide 2 shades over 48" wide

Step 2. Tools Required

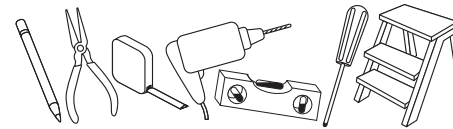

Pencil, tape measure, level, screw driver, pliers, step stool, drill.

Step 3. Installation

Your blind may be installed either inside the window frame or outside the window frame.

Wallboard or Plaster: use wall anchors.
Concrete, Stone, Brick: use a masonry drill bit and anchors or screws specifically designed for masonry (not included).

Inside Mounting:

One bracket should be positioned about 2" to 6" from each end of the head rail. For wider shades that require 3 or 4 brackets, these should be spaced evenly between the two outermost brackets.

Attach each bracket to the inner top of the window opening using the screws provided. Pre-drill the screw holes using a 5/64" drill bit. The extension brackets are not used for inside mounts.

For flush inside mounts, attach the brackets to the head rail first (see drawings and attachment instructions below), and then position the shade in the window opening as desired. Then make pencil marks at the back of each bracket. Remove the brackets by pressing on the plastic tab. Align the brackets with the pencil marks, and then screw them in place as described above.

Outside Mounting:

Attach the Extension Brackets to the wall or window framing. One bracket should be positioned about 2" to 6" from each end of the head rail. For wider shades that require 3 or 4 brackets, these should be spaced evenly between the two outermost brackets. Pre-drill the screw holes using a 5/64" drill bit.

The brackets must be level – use a Spirit Level if necessary to assure proper alignment.

Then attach a Mounting Bracket to each Extension Bracket using the nut and bolt pre-attached to each Extension Bracket.

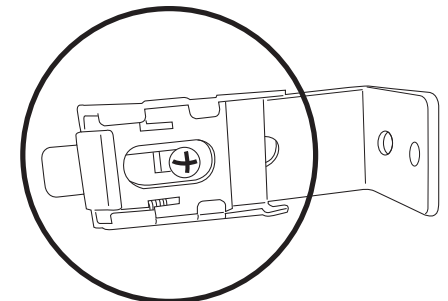
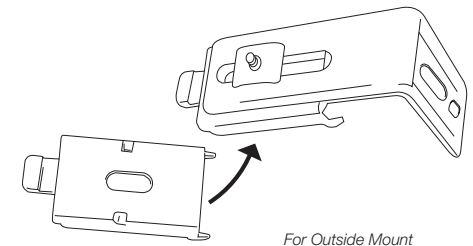

To adjust head rail extension, remove the shade from the mounting brackets by pressing on the plastic tabs at the front of each bracket. Then loosen the nut and bolt, and move the mounting brackets forward or backward as preferred.

Step 4. Securing the Head Rail

Slide the inner rear of the head rail onto the metal tabs at the back of each bracket, and then push up so that the brackets snap onto the head rail.

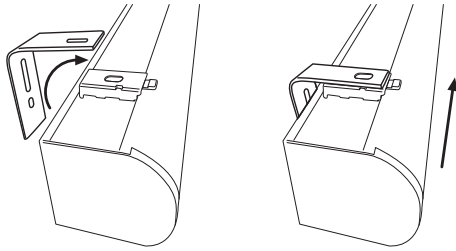

IMPORTANT FINAL STEP TO PROPERLY SECURE BRACKETS:

pull the plastic tab on the front of each bracket outward toward the front of the shade to lock the brackets in place. For inside-mounts use pliers to grasp the tabs. Check carefully to assure that each bracket is properly secured

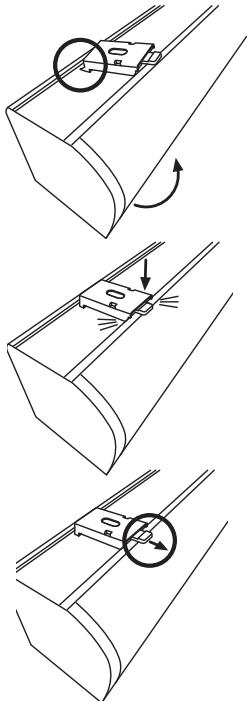

Step 5. Attach Handle

Attach the clear plastic Handle to the center of the bottom rail as illustrated.

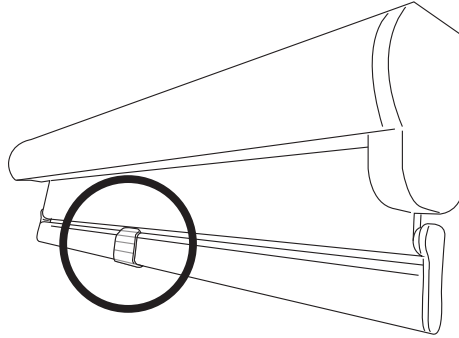

Wider shades have (2) Handles – to precisely determine the correct position for each handle, divide the total width of the shade by 4, and then attach one handle that distance from each outside edge of the bottom rail – always grasp both handles when lifting and lowering the shade.

Step 6. How to Operate

**IMPORTANT
Operating & Care Instructions for
Cordless Shades
READ CAREFULLY**

- To maintain optimal performance of the springs that make your cordless shade function, lift and lower your shade through its full range of motion – all the way up and down – frequently.

**GO SLOW!
Be sure the bottom rail handles are properly positioned as described above (step 5) - lift or lower the shade slowly and evenly, keeping the rail level, until the shade is positioned as desired.
IMPROPER OPERATION CAN DAMAGE THE SHADE.**

- If you have trouble lifting your cordless shade:
If the shade is left in one position for a long period of time, it might be necessary to lift and lower the shade several times to restore normal function.
If the shade has been fully raised for a long period of time, it might tend to spring-back (rebound) slightly from the desired length position. This can also

be remedied by lifting and lowering the shade several times.

CLEANING

To clean the shade fabric, use a feather duster or vacuum lightly using the soft brush or upholstery attachment. For spot cleaning, use warm (not hot!) water with a mild soap to damp clean.

REPLACEMENT PARTS

In the event that replacement parts are ever needed, you may call: 1-800-264-1190
Please be sure to provide the following information, if possible:

- The complete model or catalog number of your product
- A description of the product
- A description of the part needed

LIMITED LIFETIME WARRANTY

The enclosed product is warranted to the original residential retail purchaser as long as the product remains in the original window.

Covered

Lifetime: Entire product against manufacturing defects (i.e. a flaw in the product design, materials, or workmanship that causes the product to no longer function.

3 Years: Cords, including internal cords such as those found in cordless blinds or shades.

5 Years: All fabric

Not Covered

- 1. Normal wear and Tear**
- 2. Any product that fails due to:**
 - Abuse
 - Exposure to salt air
 - Improper installation
 - Accident
 - Extraordinary use
 - Improper operation
 - Alterations
 - Improper cleaning
 - Misapplication
 - Damage from pests/insects/pets
 - Improper handling
 - Misuse
- 3. Natural Wood Products that have:**
 - Loss of color intensity
 - Variations in color, grain or texture
 - Warping of wood slats in high humidity areas
- 4. Costs associated with:**
 - Product removal
 - Brand label removal
 - Product reinstallation
 - Incidental or consequential damages
 - Transportation to/from the retailer
 - Product re-measure
 - Shipping

In the event there are multiple blinds/shades in the same room, only the defective blind/shade will be replaced.

To Report Shipping Damage: If damage occurred during shipping, call the place of purchase and report within 7 calendar days, or you may be denied credit for your damaged product.

To Obtain Service: If you suspect this product has a manufacturing defect in materials or workmanship:

- Locate the sales receipt
- Call place of purchase

Any unauthorized returns will not be accepted.

Motor&Controls for Custom Dual Shades

Wire-free Rechargeable Motor System

INSTALLATION INSTRUCTIONS

INSTALL THE SHADE BEFORE ATTEMPTING TO OPERATE THE MOTOR.

Tools Required:

Tape measure, pencil, drill, drill bits, screw driver, step stool or ladder.

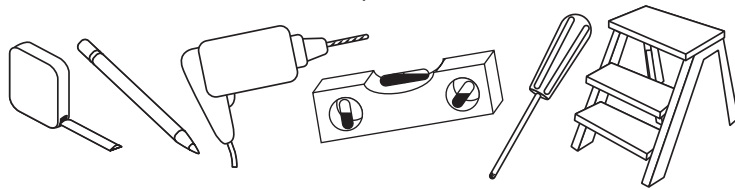

Note: use a 5/64" drill bit to pre-drill the screw holes (for attachment to a wall stud or header board). Use Wall Anchors (not included) for hollow dry wall or plaster mounting.

Step 1. Mount the Brackets [Note: If your shade has a Cassette Valance (the shade is pre-mounted in a decorative aluminum cover) locate the special instructions for installing the Cassette] Attach the brackets to the window frame, molding or ceiling as shown. The brackets are "universal" – there are no "right" and "left" brackets. Mark the screw locations with a pencil – pre-drill the screw holes using a 5/64" drill bit.

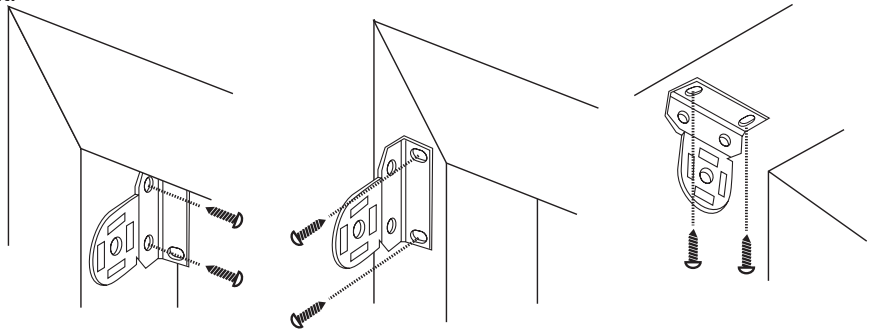

Step 2. Install the Shade

There are Hook Arms on both sides of the shade – these must be facing downward when the shade is attached to the brackets. Slide the shade upward into the brackets so that the hook arms go into the hook arm receiver holes on each bracket. Once the hook arms are through the holes, gently pull down until the hook arms have locked securely to each bracket.

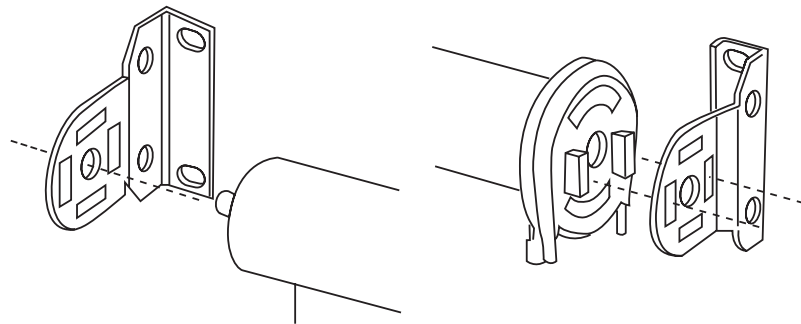

Step 3. Install the Bracket Covers

– For Outside Mount Shades Only!

Bracket covers slide onto the brackets as shown until they snap into position.

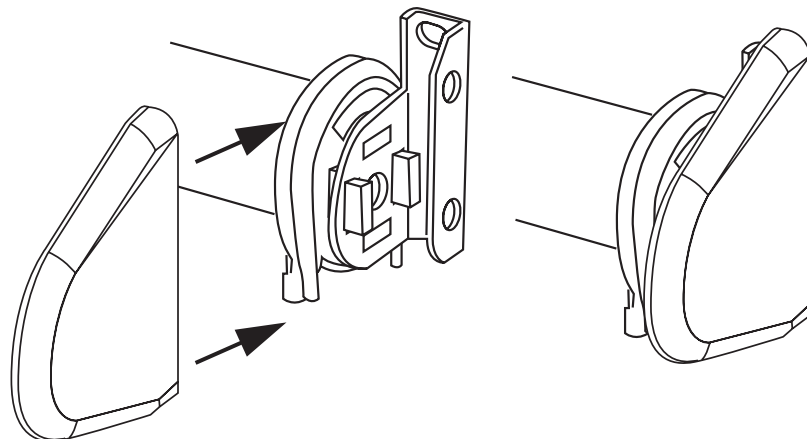

Remote Transmitters

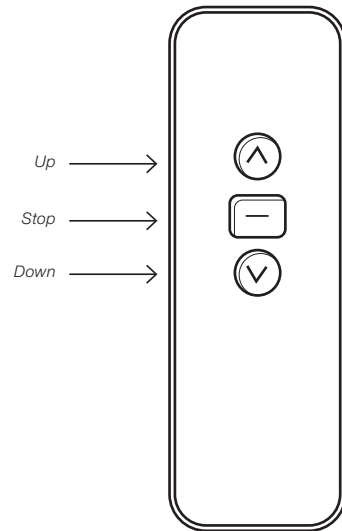

**Single Channel
Remote Control Transmitter**

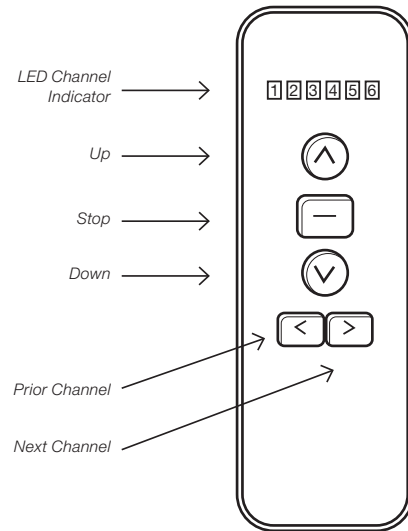

**Six (6) Channel
Remote Control Transmitter**

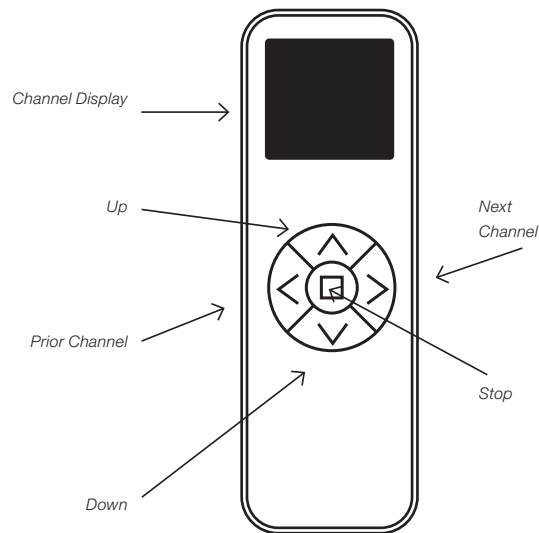

**Sixteen (16) Channel
Remote Control Transmitter**

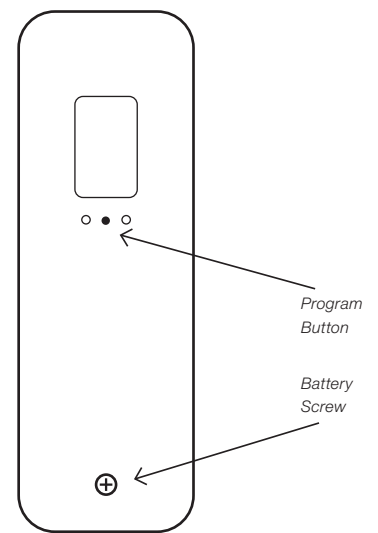

**Back of Remote Control
Transmitter**

Motor Head

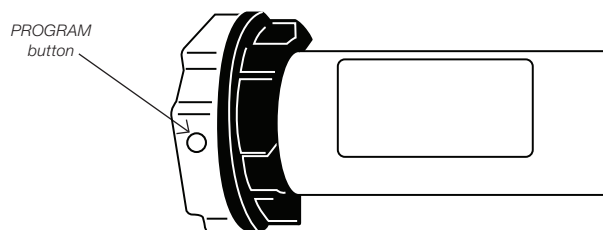

Motor&Controls for Custom Roller Shades

Wire-free Rechargeable Motor System

PROGRAMMING AND OPERATION OF RADIO TECHNOLOGY MOTORS

IMPORTANT: The Upper & Lower limit positions (full UP & DOWN positions) have been pre-set at the factory – also, a Channel Number has been assigned to each shade - therefore, it is not necessary to perform Steps 1, 2 & 3 below – however, we recommend that you read these to familiarize yourself with the basics of programming the motor and remote control and to fully understand the function of your motorized shade. Also, note that the batteries in the motor are fully charged at the factory prior to shipment.

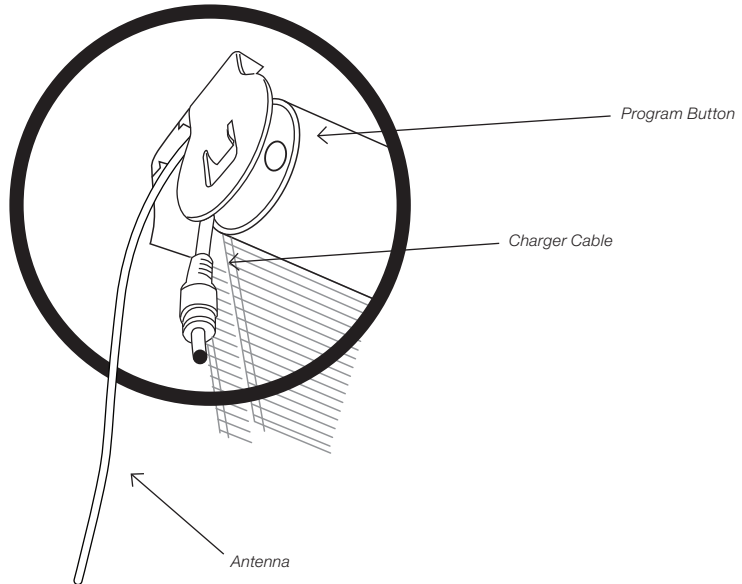

1. Channel Selection for Each Shade

When you receive your shades the channel number pre-assigned to each shade will be marked on the shade and/or carton. Per the notice above, it is not necessary to perform Steps 1, 2 & 3 as these settings are done at the factory and will require no adjustment under normal circumstances.

A channel number must be assigned to each motor/shade. The assigned numbers should be sequential starting with #1 (1, 2, 3 etc.).

Press the channel buttons/arrows to select a dedicated channel for each shade prior to mating each shade/motor to the remote controller.

2. Programming/Mating

REMINDER: the motor and remote have been pre-set at the factory – programming information for Steps 1, 2 & 3 is provided as background information only.

Identify the head of the motor housing on the left side of the shade (see drawing) - Press the PROGRAM button until the motor beeps and the shade oscillates (the shade will oscillate - a quick back and forth movement of the shade) Press the UP button on the remote (see drawing) – the shade will oscillate again – the motor and transmitter are now mated.

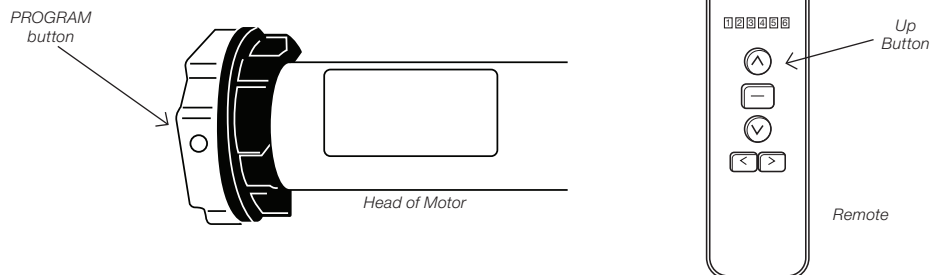

3. Setting UP and DOWN Limit Positions

NOTE: Upper and lower limit positions have been pre-set at the factory - programming information for Steps 1, 2 & 3 is provided as background information only.

Set the UP position:

Move the shade 6" to 10" below the desired upper limit by pressing the UP or DOWN arrows/buttons on the remote. Press the PROGRAM button on the back of the remote – the motor will oscillate – this puts the motor in program mode. Now move the shade up to the desired UP position and press the program button again – the motor will oscillate and the upper limit is now set.

Set the DOWN position:

Move the shade down from the upper limit position to a point 6" to 10" from the bottom, and then press the PROGRAM button on the back of the remote – the motor will oscillate and is once again in program mode. Now move the shade to the desired DOWN position and press the PROGRAM button the motor will oscillate and the lower limit is now set.

NOTE: after all limits are set, see the remote control operating instructions below.

4. Setting Intermediate Positions & Other Settings

Setting INTERMEDIATE positions

Up to (4) intermediate positions can be set.

Move the shade at least 6 inches away from the previously set limits – press the PROGRAM button on the rear of the remote – the motor will oscillate and is now in program mode.

Now move the shade to any desired intermediate STOP position and press the PROGRAM button again – the motor will oscillate and the intermediate STOP position is now set.

Repeat this process to set additional intermediate STOP positions

Erasing Limits:

Note: the 1st/Upper limit cannot be erased – it can only be eliminated by deleting all memory

Move the shade to the limit position – that you wish to erase – press and hold the PROGRAM button on the rear of the remote for approximately 7 seconds – the motor will oscillate twice, and the limit has been erased.

Deleting Memory:

Press the program button on the head of the motor 4 times, and then press a fifth time and hold the button down until the motor oscillates twice. All memory is now erased.

Sleep Mode (to enable the control of more than one motor on a single channel):

Press and hold the program button on the head of the already programmed motor – keep holding the button when the motor beeps and oscillates until you hear a long beep – the motor is now in Sleep Mode.

Program the new motor by using the exact same steps as above to begin programming the second motor. Now set the limits on the new motor as described above. When you have finished setting the limits on the newly programmed motor, continue in the same fashion until all motors that you wish to have on that channel are programmed.

You then begin waking up each motor by pressing the program button on the head of the motor until the motor beeps – then press the UP button on the remote on the desired channel.

Using the Remote Control Transmitter

Press the UP/DOWN button once and the shade will move to the next pre-set limit position.

Press the UP/DOWN button twice at the speed of once per second and the shade will move to the UP or DOWN limit position without stopping at any intermediate position.

When the up position has been reached, the UP button becomes non-functional, and when the down position has been reached the DOWN button becomes non-functional.

Controlling Multiple Shades Simultaneously

6 Channel Remote: press the channel selector until all six lights are lit to control up to 6 shades at the same time using the remote control as described above.

16 Channel Remote: press the channel selector button until "CC" appears in the display window to control up to 16 shades at the same time using the remote control as described above.

Operating the Shade

To raise and lower the shade, use the remote control as described above.

Charging the Batteries

Connect the AC Charger to the Charger Cable attached to the motor head – charge for 8 hours.

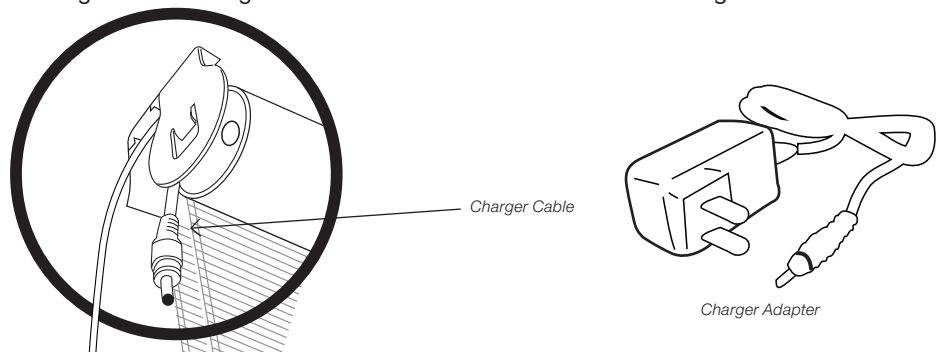

Motor&Controls for Custom Roller Shades

Wire-free Rechargeable Motor System

Installation/Replacement of the Remote Control Battery

Remove the cover on the rear of the remote by removing the screw and sliding the back plate upward slightly – install a 3V [CR2032] disk type battery as illustrated.

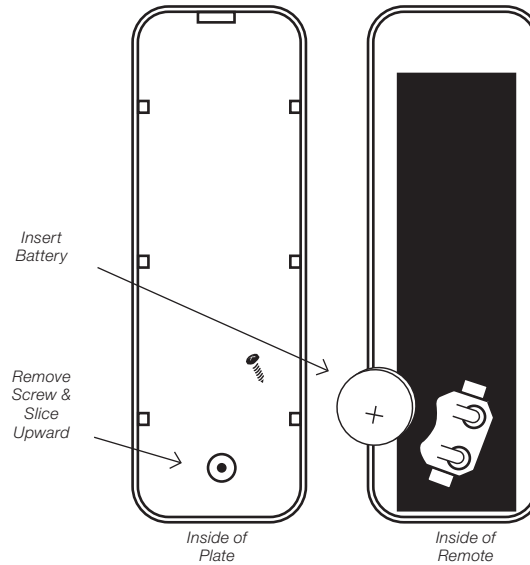

Installation of Optional Wall Mount Holder

Attach the remote holder using the screws provided (use wall anchors for hollow dry wall), or peel the foil off the adhesive pad on the back of the remote holder and press it into place on any clean flat surface.

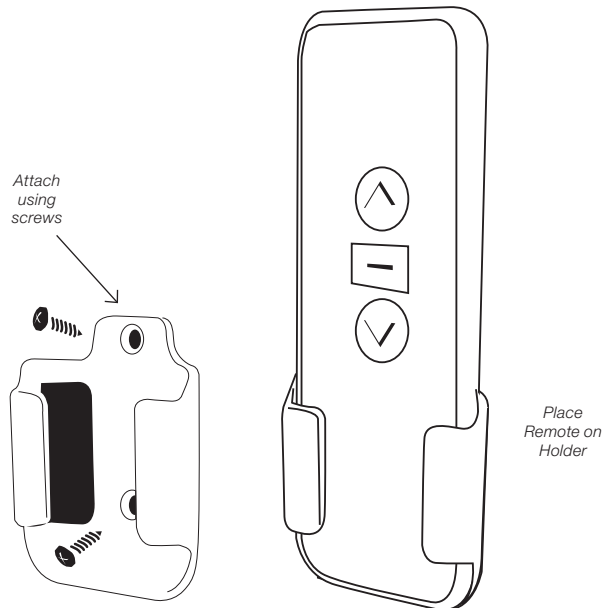

CUSTOMER SERVICE: 1-800-264-1190

General Safety Instructions for Motorized Shades

- Do not expose the motor or transmitter to moisture or extreme temperatures
- Do not allow children to play with this device
- Use or modification outside the scope of this instruction manual will void the warranty
- If cable or power connector is damaged, do not use
- Keep the antenna straight and clear from metal objects

Statement Regarding FCC Compliance

This device complies with Part 15 of the FCC rules. Operation is subject to the following two conditions:

- 1) This device may not cause interference, and
- 2) This device must accept any interference received, including interference that may cause undesired operation.

Note:

This equipment has been tested and found to comply with 15 of the FCC Rules. These limits are designed to provide reasonable protection against harmful interference in a residential installation. This equipment generates, uses and can radiate radio frequency energy and, if not installed and used in accordance with the instructions, may cause harmful interference to radio communications.

However, there is no guarantee that interference will not occur in a particular installation. If this equipment does cause harmful interference to radio or television reception, which can be determined by turning the equipment off and on, the user is encouraged to try to correct the interference by one or more of the following measures:

- Reorient or relocate the receiving antenna.
- Increase the separation between the equipment and the receiver.
- Connect the equipment into an outlet on a circuit different from that to which the receiver is connected.
- Consult the dealer or an experienced radio/TV technician for help.

Any changes or modifications not expressly approved by the party responsible for compliance could void the users authority to operate the equipment.

Cleaning

Dusting: Vacuum using the soft brush attachment.

Washing (applies to vinyl or vinyl coated shade material): Use a cloth, sponge or soft brush and a mild detergent. Use warm or cold water, not hot water. Place toweling on the floor or window sill and wash the blind in sections.

REPLACEMENT PARTS

In the event that replacement parts are ever needed, you may call: 1-800-264-1190

Please be sure to provide the following information, if possible:

- The complete model or catalog number of your product
- A description of the product
- A description of the part needed

LIMITED LIFETIME WARRANTY

The enclosed product is warranted to the original residential retail purchaser as long as the product remains in the original window.

Covered

Lifetime: Entire product against manufacturing defects (i.e. a flaw in the product design, materials, or workmanship that causes the product to no longer function.

3 Years: Cords, including internal cords such as those found in cordless blinds or shades.

5 Years: All fabric

3 Years: Battery Operated Motors

Not Covered

1. Normal wear and Tear

2. Any product that fails due to:

- Abuse
- Alterations
- Exposure to salt air
- Improper cleaning
- Improper installation
- Misapplication
- Accident
- Damage from pests/insects/pets
- Extraordinary use
- Improper handling
- Improper operation
- Misuse

3. Natural Wood Products that have:

- Loss of color intensity
- Variations in color, grain or texture
- Warping of wood slats in high humidity areas

4. Costs associated with:

- Product removal
- Transportation to and from the retailer
- Brand label removal
- Product re-measure
- Product reinstallation
- Shipping
- Incidental or consequential damages

Motor&Controls for Custom Roller Shades

Wire-free Rechargeable Motor System

In the event there are multiple blinds/shades in the same room, only the defective blind/shade will be replaced

To Report Shipping Damage:

If damage occurred during shipping, call the place of purchase and report within 7 calendar days, or you may be denied credit for your damaged product.

To Obtain Service:

If you suspect this product has a manufacturing defect in materials or workmanship:

- Locate the sales receipt
- Call place of purchase

Any unauthorized returns will not be accepted.

Warranty Remedy:

This shall be your sole remedy under this limited warranty.

If this product is found to have a manufacturing defect in materials or workmanship, we will, at our discretion, do one of the following:

- Repair the product
- Replace the product
- Refund the cost of the product

Colors may vary from lot to lot and may not exactly match sample swatches or previous purchases.

Discontinued items or color selections will be replaced with the closest equivalent current product.

Your rights under state law: This lifetime limited warranty gives you specific legal rights, and you may have other rights which vary from state to state. Some states do not allow limitations on how long a warranty lasts, so the above limitations may not apply to you. No agent, representative, dealer

or unauthorized employee has the authority to increase or alter the obligation of this warranty. This lifetime limited warranty supersedes any previous versions

WARNING

STRANGULATION HAZARD — Young children can be strangled by cords. Immediately remove this product if a cord longer than 22 cm or a loop exceeding 44 cm around becomes accessible.

 **SelectBlinds®**

Troubleshooting

Problem	Possible Fix
Shade moving in the wrong direction	Reset the motor to factory spec and erase all limits, then program from the beginning.
Shade Not stopping at desired height (Reset Limit)	Top Limit can not be reset without erasing all limits and starting from the beginning, Take the shade to the incorrect limit, Press and hold the program button on the back of the remote until the shade jogs, move the shade to the desired height then press and hold the program button until the shade jogs again. The limit has been reset.
Motor has no response to remote	Press and hold the program button on head of motor, see if it Jogs, if it does then walk them through programming from the beginning Check the Antenna, make sure it is not kinked or touching metal.
Still not working, plug the motor in.	See if motor operates or can be programmed
Switch motor to another channel	If remote already has 1 motor on the desired channel, put that motor in sleep mode and then erase the memory of the motor that is to be switched and joined on another channel. Program to the new channel then wake the other motor up.
Motor begins to beep, Power is getting low	Plug the motor in as soon as possible, if the power drops to zero voltage the memory could be lost and the motor will have to be reprogrammed.

Smart WiFi Hub Instructions

1. Download & Install "P2 POWERMATE" APP on your cellphone

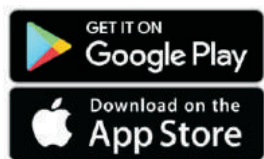

powermate smart hub



powermate

powermate APP

- (1) Search for "P2 POWERMATE" on the App Store or Google play
- (2) Download "P2 POWERMATE" and install the APP on your phone

2. Register and login to the P2 POWERMATE APP



- (1) When installation is complete open P2 POWERMATE
- (2) Create an account using your e-mail address – enter a password that should include letters and numbers only, no signs or special characters
- (3) Login in to your account (after the account is established you will login to the APP directly)

3. Link the P2 POWERMATE hub to the POWERMATE APP

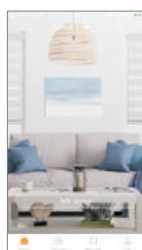

- (1) Choose "Add device" on desktop

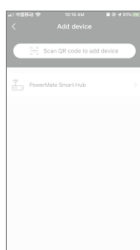

- (2) Choose P2 POWERMATE Smart Hub



- (3) Choose "AllOne Pro"



- (4) Power on the P2 POWERMATE hub



- (5) Press and hold the central button on the hub until the circular light turns RED and Flashes



- (6) Choose "Next" on the P2 POWERMATE APP



- (7) Choose "Join" to enable the hub to access your Wi-Fi network
Tip: Make sure your network is available, not restricted to assure access



- (8) Select your Wi-Fi network and input your Wi-Fi password



- (9) The P2 POWERMATE hub will connect to your Wi-Fi network automatically. When you see "Added successfully" on the P2 POWERMATE APP, choose "Done"

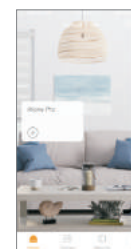
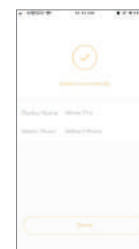

- (10) The APP is linked to the P2 POWERMATE hub when Allone Pro appears on the desktop

4. Add your shades to the P2 POWERMATE APP



- (1) Choose "Allone Pro" on the APP desktop

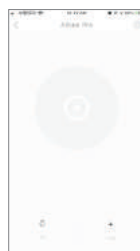

- (2) Choose "+ Add" at the menu bottom right corner

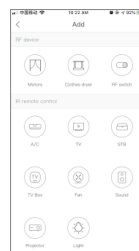

- (3) Choose "Motor" device

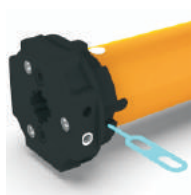

- (4) Now press the "programming button" on motor head for 1 second - the shade will oscillate one time. Then tap "pairing" on P2 POWERMATE APP. If the shade is successfully added to the APP, the shade will oscillate one more time.
If not, repeat the step 4 operation.



- (5) Choose "Response has been stored" when the shade is successfully added to APP.

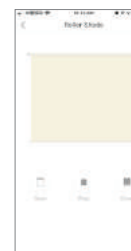

- (6) The shade has been added to the P2 POWERMATE APP. Confirm that you can now control the shade using the APP, and then proceed to add additional shades if applicable.

5. Family “Member Permission” management

Note that the set-up account is the one and only administrator – only the administrator's login can make changes to the APP. However, the administration account can add family members with their own ID, and they can then control the shades from their phones or tablets.

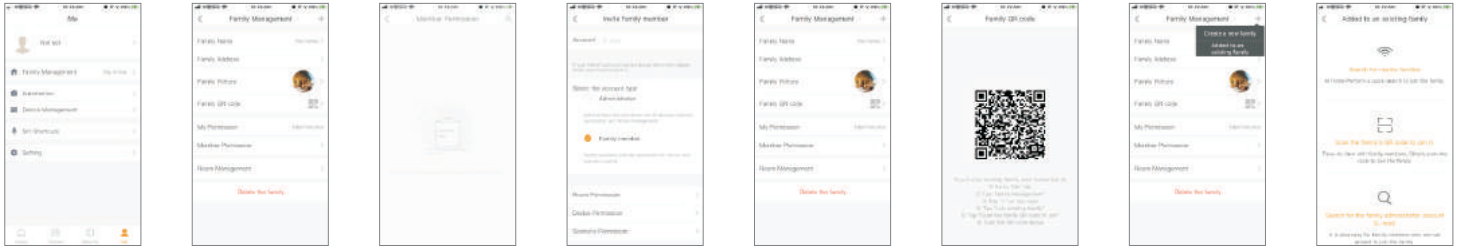

(1) Choose “Me” on the P2 POWERMATE desktop, and then Select “family Management” menu

(2) Choose “Member Permission”

(3) Tap “+” family members at the top right corner of the screen

(4) Input your family “Account e-mail address” then go to invitation to your family member

(5) When your family member receives and accepts the invitation, the Administration account shows the family QR Code that the family member will scan. The family member taps “+” at the top right corner, and chooses “Add to an existing family”. Choose “scan the family’s QR code to join it”, and then scan the code on the administrators screen.

6. “Siri Shortcut” Voice Command Management

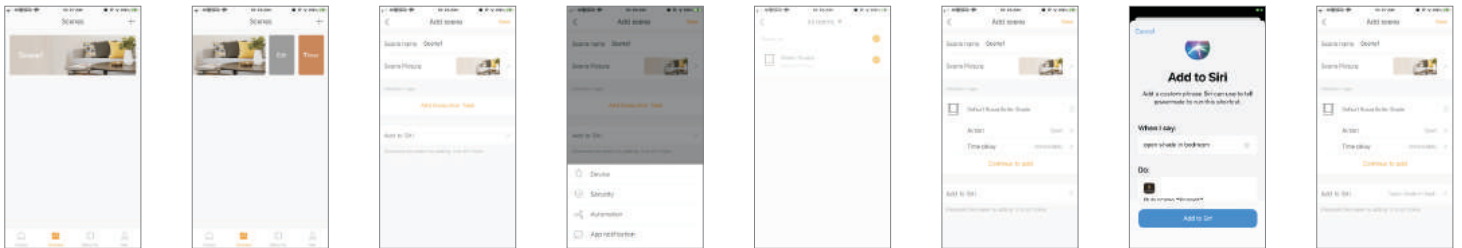

(1) Choose “Scenes” on the P2 POWERMATE desktop. Create a scene.

(2) Slide the “scene” icon to left, and then choose “Edit” scene

(3) Add Execution Task

(4) Choose “Device” and then select the shade you want to add to this scene

(5) Choose an “Action” for the shade you selected. Then Add to Siri.

(6) In the Add to Siri menu, you can edit the “Siri shortcut command”. For example: “open shade in bedroom”. After all tasks are set up, save the scene. Now you can let Siri control your shades.

7. Link to “Amazon Alexa” & “Google home” voice control device

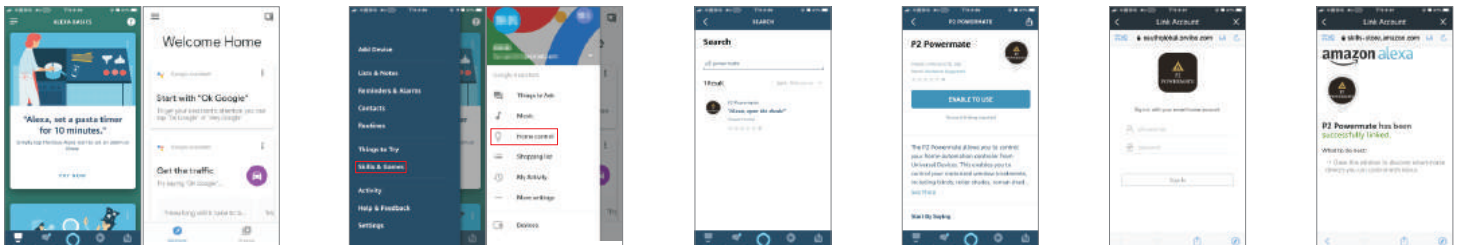

(1) Login in your “Amazon Alexa” or “Google home” APP

(2) “Amazon Alexa” add “Skills & Games” “Google Home” add “Home control”

(3) Search “p2 powermate”

(4) Choose “ENABLE TO USE”

(5) Input your “p2 powermate” account and password, then sign in. Now P2 Powermate had been linked to your “Alexa” or “Google Home” voice control device.

SETUP CODE CODE DE CONFIGURATION

SBCAN

Getting to know your Smart Controller

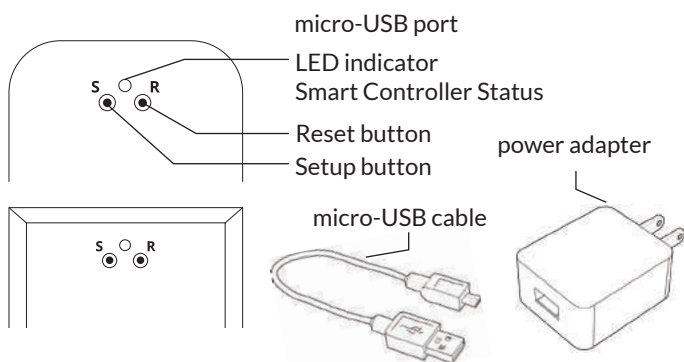

Smart Controller Status:
Flashing blue - Hotspot available
Flashing green - Connecting to the WiFi network
Pulsing cyan/blue-green - Connected to the Internet

Getting Started

- 1 Download the Neo Smart Blinds app**

Download the app to your phone or tablet by searching **Neo Smart Blinds** on Google Play or the App Store.
Note: Do not install Neo Smart Blinds Blue
- 2 Plug in your Smart Controller in reach of your home WiFi**

Choose a place not too far from your home router or a place you know has good WiFi signal strength. You will be able to change its location after, if necessary.
- 3 Create an account and choose the setup code written on the cover**

After opening the app, tap on Create one to create a new account. Enter a valid email address and choose a password, select the region time zone from the place where the Smart Controller will be located. Choose the setup code written in the cover and tap on Register.
- 4 Follow the app step by step to add the Smart Controller**

Have in hand the home WiFi password. It will be necessary to connect the Smart Controller to the Internet.
Note: Some Android users won't be connected quickly to the hotspot. If it is the case, please wait about 10 seconds before returning to the app. During this time, your device may notify you that the hotspot does not have Internet access, and will prompt you whether you want to remain connected. You need to select the option that will allow you to keep connected before returning to the app.

System requirements

- A strong WiFi signal (3 bars or more) in the location where you will setup your Smart Controller.
- The Smart Controller only supports 2.4GHz WiFi (IEEE 802.11b/g/n), not 5GHz. WiFi security needs to be set to WPA-PSK or WPA2-PSK.
- A smartphone or tablet running Android 5.0 (Lollipop) or higher, or iOS 8 or higher is needed.

Troubleshooting

The home WiFi doesn't appear in the step 4

Try rescanning, if the problem persists, you will need to reposition the Smart Controller to a place with stronger WiFi signal. In this case, exit the process (tap on the menu, then tap Your Rooms), replace the Smart Controller and start over.

The Smart Controller LED in the bottom is not blinking blue

The process fails in the last step

Press the S button for 10 seconds, then press the R button once and start over. Pay special attention when typing the WiFi password.

Need more help?

Visit neosmartblinds.com/smartcontroller for detailed instructions about how to use the app and troubleshooting.

Integrations

Smart home devices

Visit neosmartblinds.com/smartcontroller-integrations for detailed information about connecting to Amazon Alexa, Google Home and other systems.

Control4

Please send an email to tech@neosmartblinds.com with your name, your email and your company's name. This information is necessary to always send to you any further driver update.

Legal Information

FCC

This equipment has been tested and found to comply with the limits for a Class B digital device, pursuant to Part 15 of the FCC Rules. These limits are designed to provide reasonable protection against harmful interference in a residential installation. This equipment generates uses and can radiate radio frequency energy and, if not installed and used in accordance with the instructions, may cause harmful interference to radio communications. However, there is no guarantee that interference will not occur in a particular installation. If this equipment does cause harmful interference to radio or television reception, which can be determined by turning the equipment off and on, the user is encouraged to try to correct the interference by one of the following measures:

- Reorient or relocate the receiving antenna.
- Increase the separation between the equipment and receiver.
- Connect the equipment into an outlet on a circuit different from that to which the receiver is connected.
- Consult the dealer or an experienced radio/TV technician for help

Contains transmitter module FCC ID: COFWNMNB11

To comply with FCC/IC RF exposure limits for general population/uncontrolled exposure, the antenna(s) used for this transmitter must be installed to provide a separation distance of at least 20 cm from all persons and must not be co-located or operating in conjunction with any other antenna or transmitter.

IC

This device complies with Industry Canada's licence-exempt RSSs. Operation is subject to the following two conditions:

- This device may not cause interference; and
- This device must accept any interference, including interference that may cause undesired operation of the device.

This device meets the exemption from the routine evaluation limits in section 2.5 of RSS102 and users can obtain Canadian information on RF exposure and compliance.

Contains transmitter module IC: 10293A-WMNB11

This End equipment should be installed and operated with a minimum distance of 20 centimeters between the radiator and your body.

